

# Installation

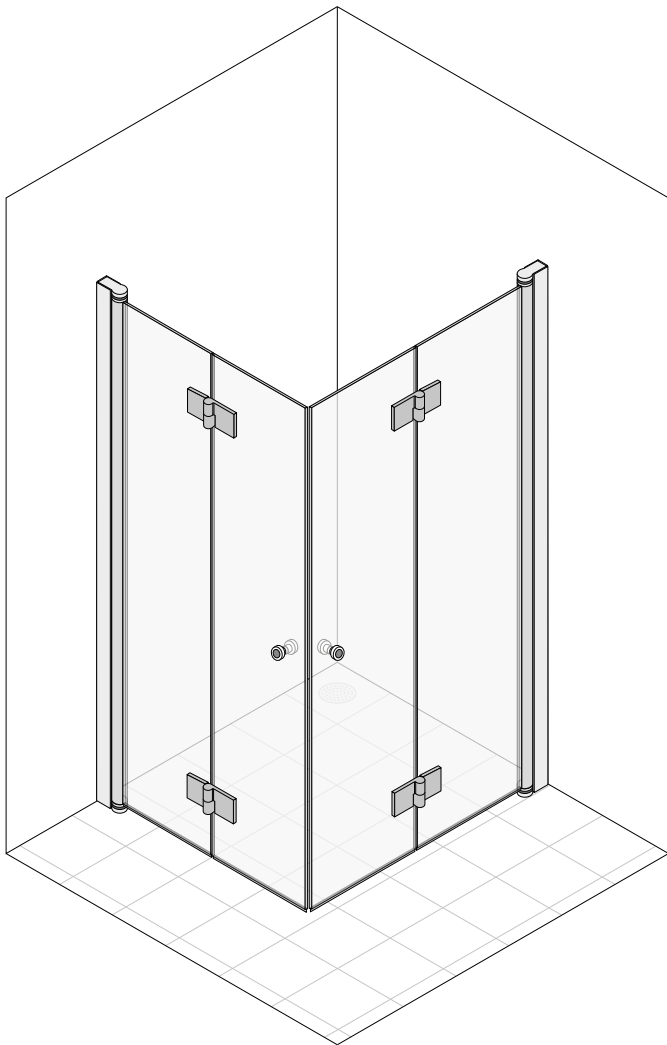

Arrow Scandinavien AB  
Tel: +46 (0)31 330 00 10  
www.arrowshower.com

## Twice Corner



## Twice Nisch

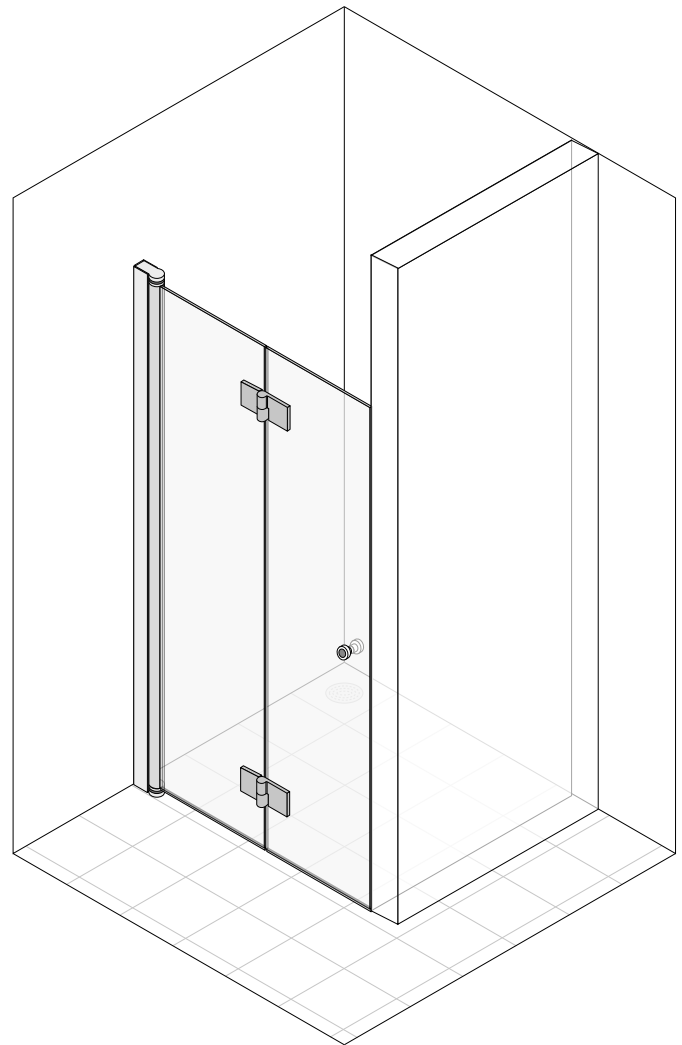

### SVENSKA

**(SV) Installationsanvisning för Arrow duschvägg.**

Vi förbättrar ständigt våra installationsanvisningar.  
Besök vår hemsida för senaste versionen.

### ENGLISH

**(EN) Installation instructions for Arrow shower wall.**

We constantly improve our installation instructions.  
Visit our website for the latest version.

(SV) Artikelnummer:  
(EN) Code:

(SV) Storlek (EN) Size	<b>L</b>	<b>R</b>
700	5371-7	5361-7
800	5371-8	5361-8
900	5371-9	5361-9
1000	5371-10	5361-10
1100	5371-11	5361-11
1200	5371-12	5361-12

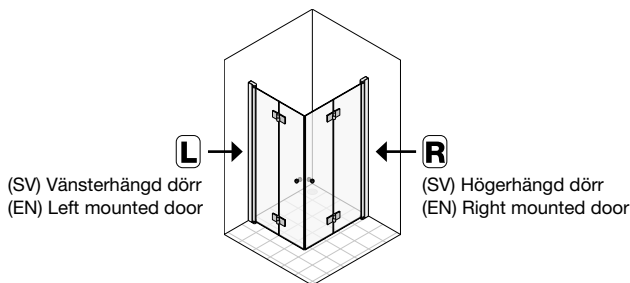

## Twice Corner

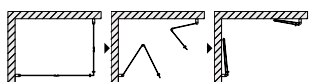

(SV) Storlek (EN) Size	(SV) Justerbarhet (EN) Adjustability
<b>700</b> <b>L × R</b>	<b>X<sub>1</sub> × X<sub>2</sub></b>
<b>700 × 700</b>	685-705 × 685-705
700 × 800	685-705 × 785-805
700 × 900	685-705 × 885-905
700 × 1000	685-705 × 985-1005
700 × 1100	685-705 × 1085-1105
700 × 1200	685-705 × 1185-1205
<b>800</b> <b>L × R</b>	<b>X<sub>1</sub> × X<sub>2</sub></b>
800 × 700	785-805 × 685-705
<b>800 × 800</b>	785-805 × 785-805
800 × 900	785-805 × 885-905
800 × 1000	785-805 × 985-1005
800 × 1100	785-805 × 1085-1105
800 × 1200	785-805 × 1185-1205
<b>900</b> <b>L × R</b>	<b>X<sub>1</sub> × X<sub>2</sub></b>
900 × 700	885-905 × 685-705
900 × 800	885-905 × 785-805
<b>900 × 900</b>	885-905 × 885-905
900 × 1000	885-905 × 985-1005
900 × 1100	885-905 × 1085-1105
900 × 1200	885-905 × 1185-1205

(SV) Storlek (EN) Size	(SV) Justerbarhet (EN) Adjustability
<b>1000</b> <b>L × R</b>	<b>X<sub>1</sub> × X<sub>2</sub></b>
1000 × 700	985-1005 × 685-705
1000 × 800	985-1005 × 785-805
1000 × 900	985-1005 × 885-905
<b>1000 × 1000</b>	985-1005 × 985-1005
1000 × 1100	985-1005 × 1085-1105
1000 × 1200	985-1005 × 1185-1205
<b>1100</b> <b>L × R</b>	<b>X<sub>1</sub> × X<sub>2</sub></b>
1100 × 700	1085-1105 × 685-705
1100 × 800	1085-1105 × 785-805
1100 × 900	1085-1105 × 885-905
1100 × 1000	1085-1105 × 985-1005
<b>1100 × 1100</b>	1085-1105 × 1085-1105
1100 × 1200	1085-1105 × 1185-1205
<b>1200</b> <b>L × R</b>	<b>X<sub>1</sub> × X<sub>2</sub></b>
1200 × 700	1185-1205 × 685-705
1200 × 800	1185-1205 × 785-805
1200 × 900	1185-1205 × 885-905
1200 × 1000	1185-1205 × 985-1005
1200 × 1100	1185-1205 × 1085-1105
<b>1200 × 1200</b>	1185-1205 × 1185-1205

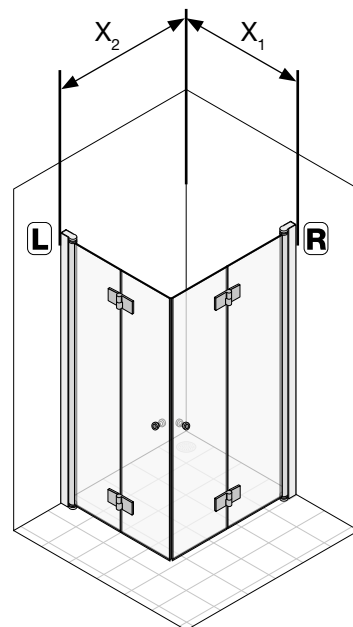

(SV) X<sub>1</sub> = L-dörrens justerbarhet  
X<sub>2</sub> = R-dörrens justerbarhet

(EN) X<sub>1</sub> = L door adjustability  
X<sub>2</sub> = R door adjustability

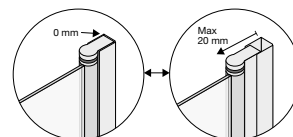

## Twice Nisch

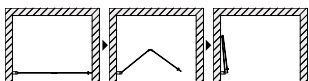

(SV) Storlek (EN) Size	(SV) Justerbarhet (X) (EN) Adjustability (X)
700	672-692
800	772-792
900	872-892
1000	972-992
1100	1072-1092
1200	1172-1192

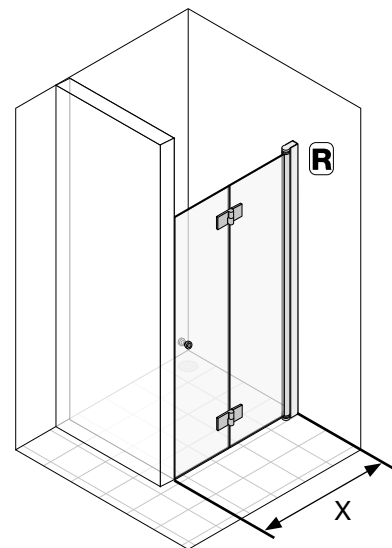
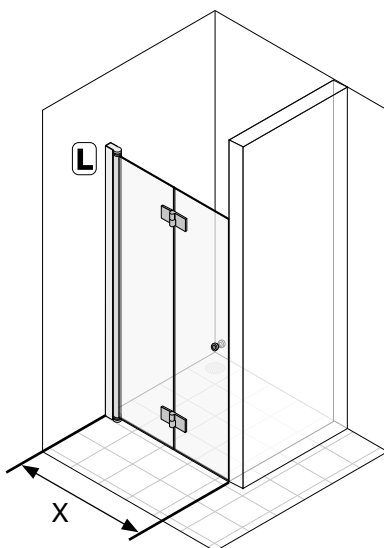
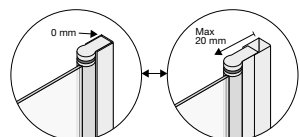

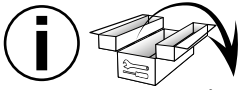
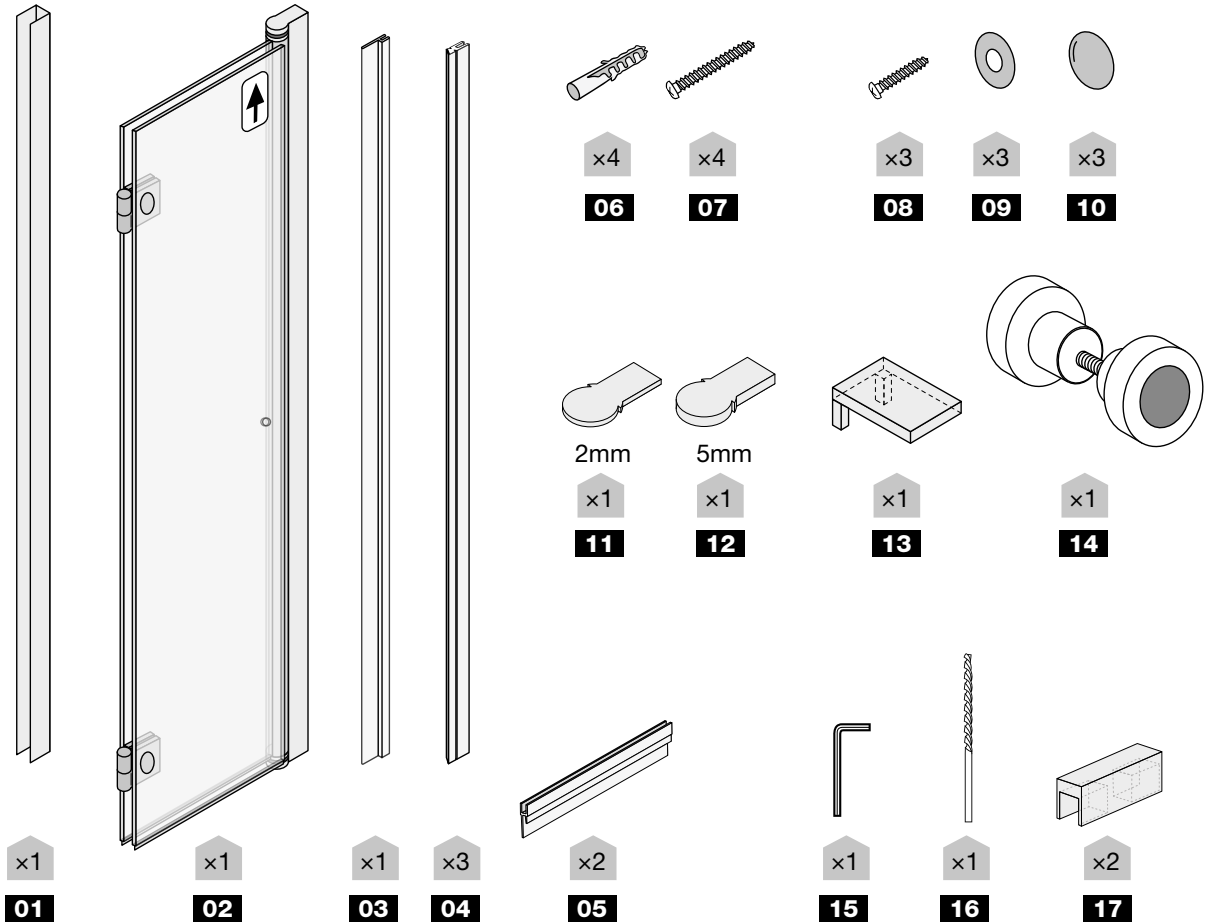
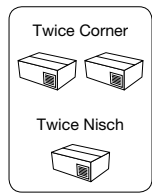
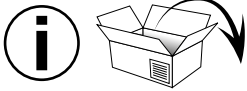

(SV) Medföljer ej.  
(EN) Not included.

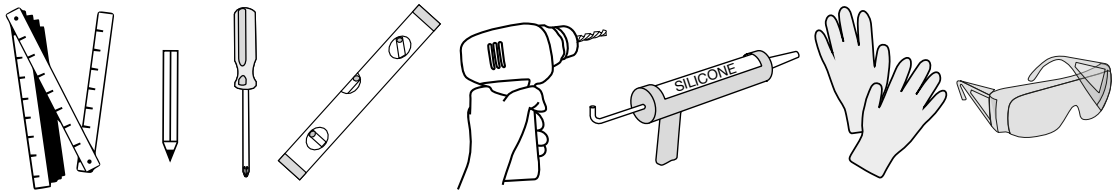

**(SV) Våtrumsvägg:** 1) Borra bara genom yt- och tätskiktet. 2) Fyll med tätmassa. 3) Skruva så att skruven fäster i plywooden.

**(EN) Wet area wall:** 1) Drill only through surface and waterproofing. 2) Fill with sealant. 3) Screw should attach to the plywood.

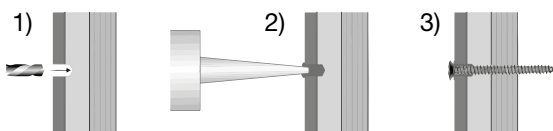

**(SV) Vägg med reglar:**  
1) Borra. 2) Tätmassa. 3) Skruva.

**(EN) Wall with beams:**  
1) Drill. 2) Sealant. 3) Screw.

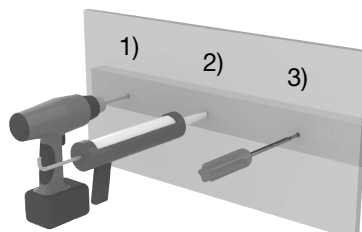

**(SV) Betongvägg:** 1) Borra. 2) Tätmassa. 3) Plugg. 4) Silikon. 5) Skruva.

**(EN) Concrete wall:** 1) Drill. 2) Silicone. 3) Plug. 4) Sealant. 5) Screw.

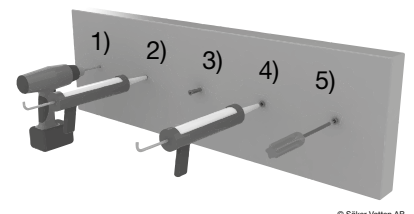

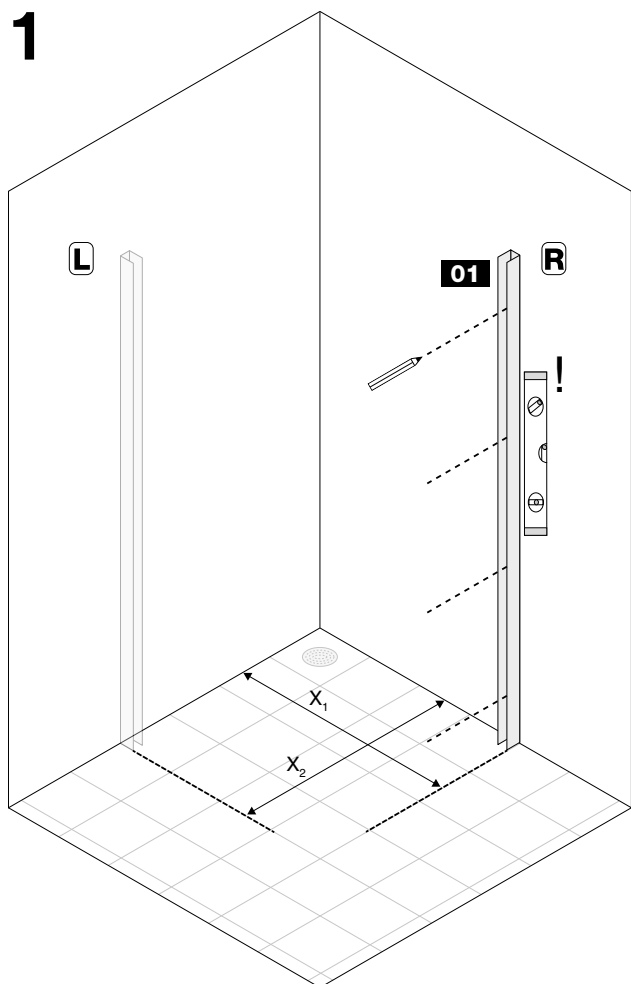
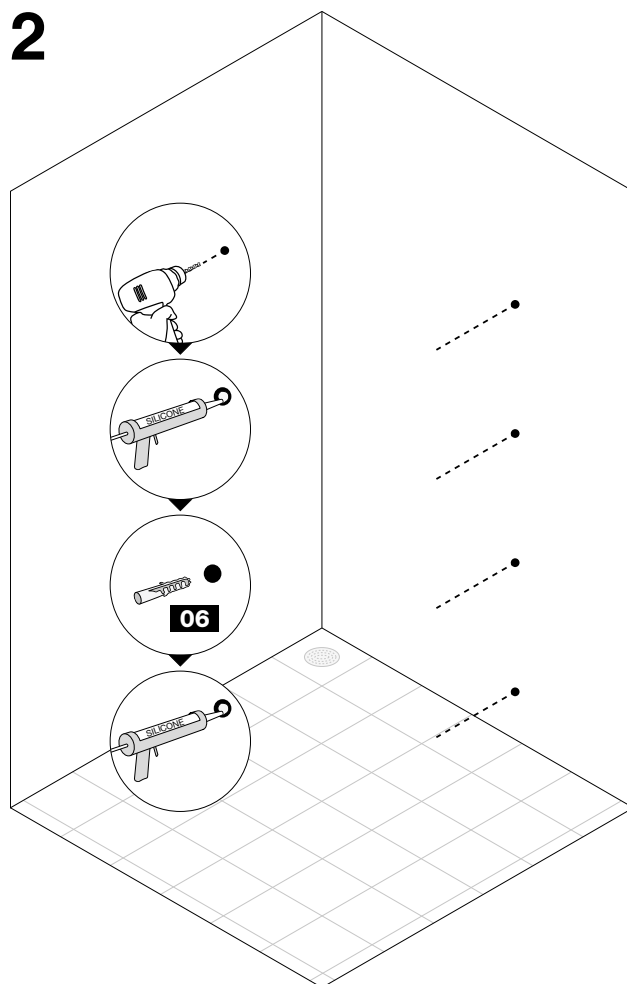
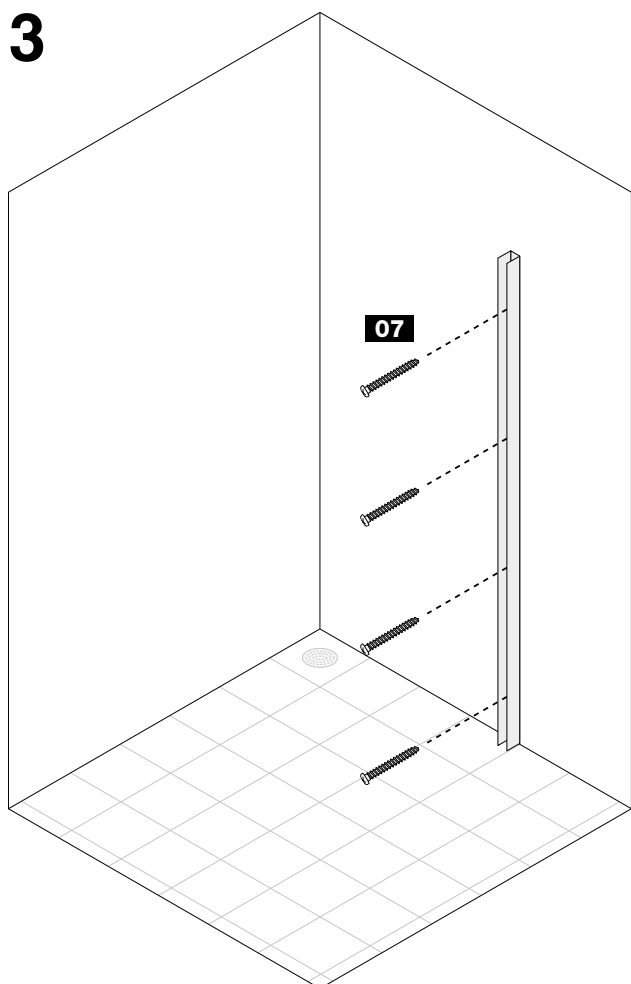
**1****2****3****4**

5

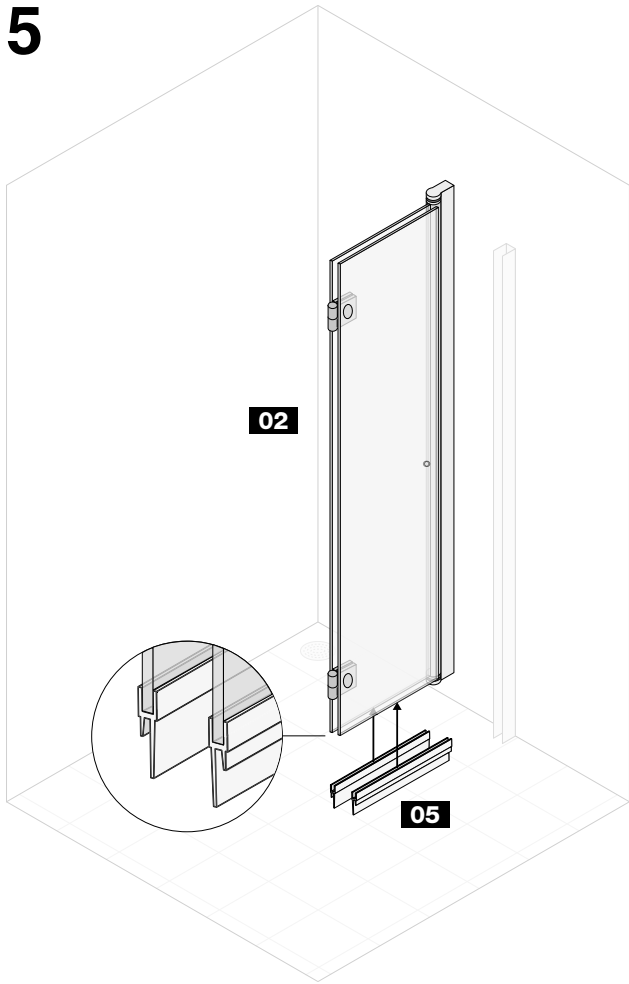

6

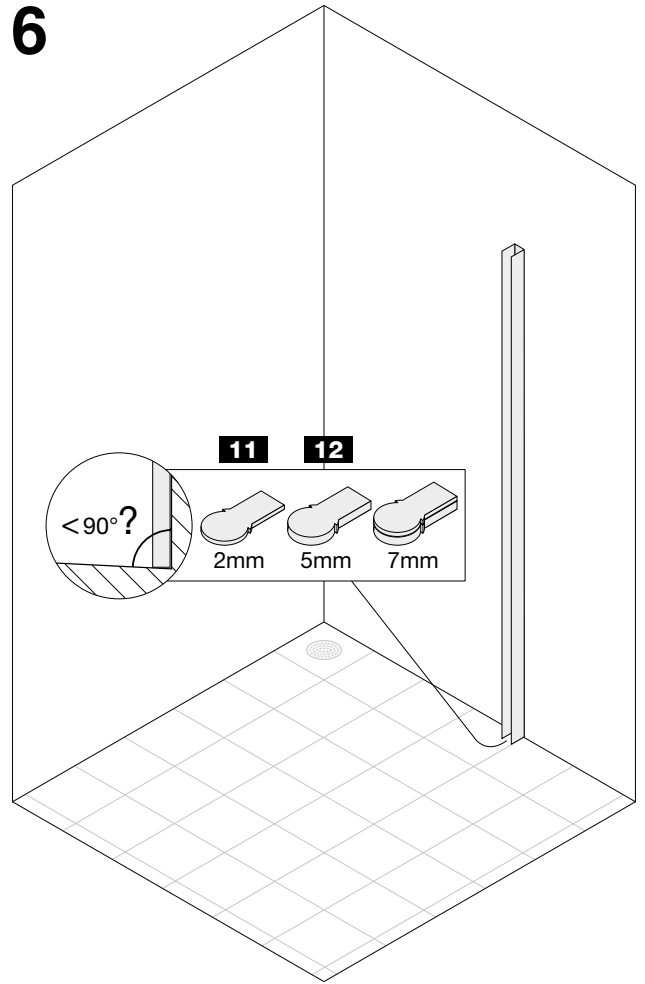

7

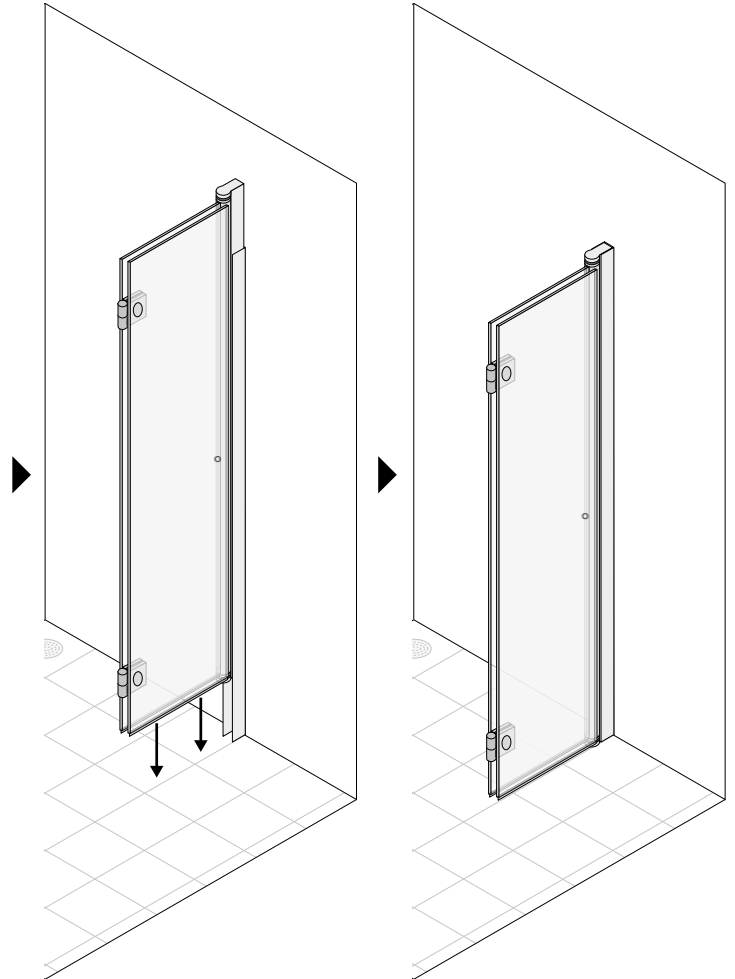
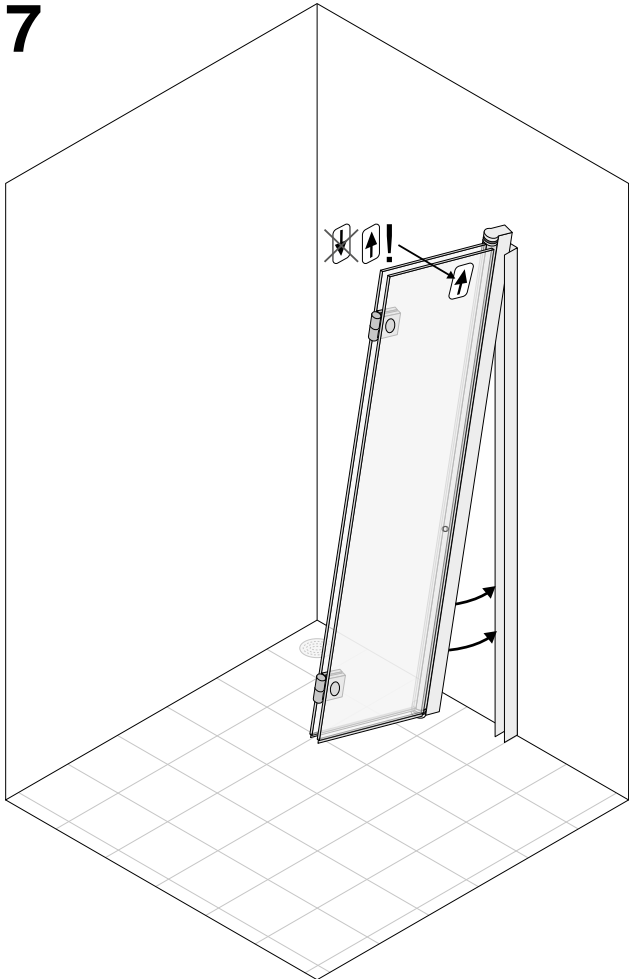

# 8

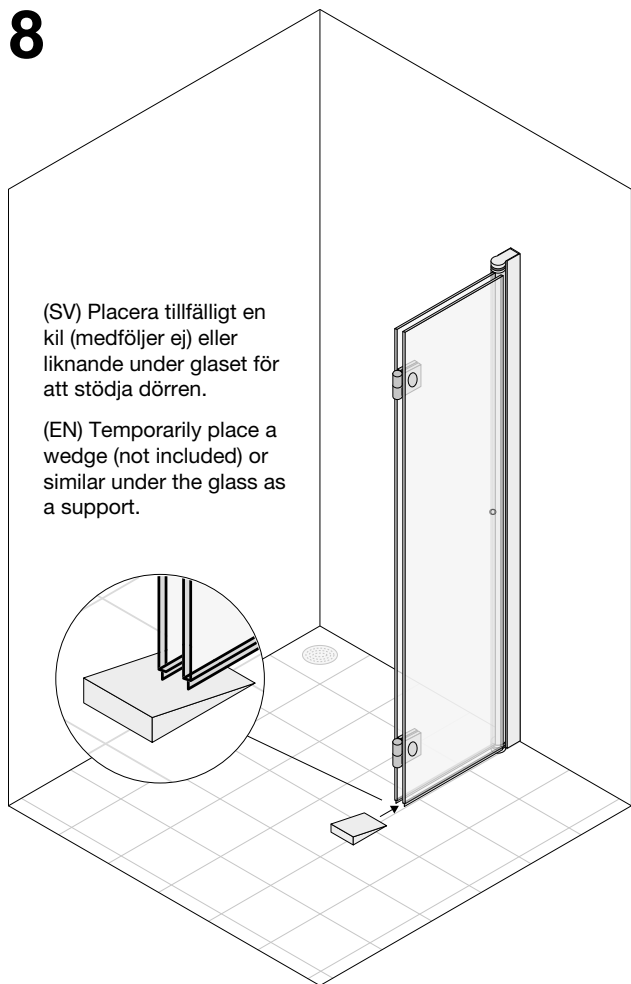

(SV) Placera tillfälligt en kil (medföljer ej) eller liknande under glaset för att stödja dörren.

(EN) Temporarily place a wedge (not included) or similar under the glass as a support.

# 9

(SV) **SÄKERSTÄLL ATT:**

Det undre gångjärnet är låst:  
 Dra åt insexskruven **moturs**.

(EN) **MAKE SURE THAT:**

The lower hinge is locked:  
 Tighten the hex screw **anti-clockwise**.

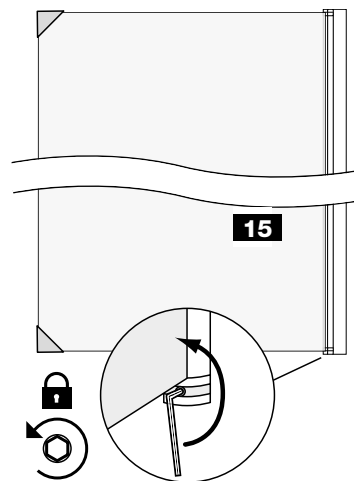

! (SV) **Låsa:** moturs.  
 (EN) **Lock:** anti-clockwise.

# 10 (SV) ENDAST VID BEHOV!

Dörrens nolläge är vid leverans inställt till standardvinkel. Nolläget är den vinkel där dörren sänks och stannar när den stängs. Vid öppning höjs dörren. Nedan ser du hur man kan ändra nollägets vinkel, om detta skulle behövas.

(EN) **ONLY IF NECESSARY!**

The door's neutral position is set to standard angle at delivery. The neutral position is the angle where door is lowered and staying when it is closed. The door will raise when opening it. The instructions below show how to change the angle of the neutral position, if this is needed.

(SV) 1) Lås upp det undre gångjärnet genom att skruva insexskruven **medurs** med medföljande insexnyckel.

(EN) 1) Unlock the bottom hinge by screwing the hex screw **clockwise** with the enclosed hex key.

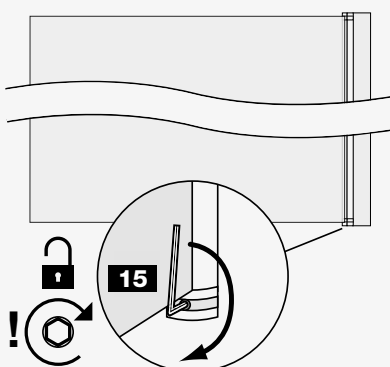

! (SV) **Låsa upp:** medurs.  
 (EN) **Unlock:** clockwise.

(SV) 2) Vrid dörren till önskad vinkel (nytt nolläge).

(EN) 2) Turn the door to the desired angle (new neutral position).

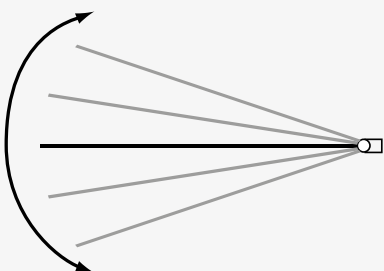

(SV) 3) Lås vinkeln genom att skruva insexskruven **moturs** i det undre gångjärnet.

(EN) 3) Lock the new position by screwing the hex screw **anticlockwise** in the bottom hinge.

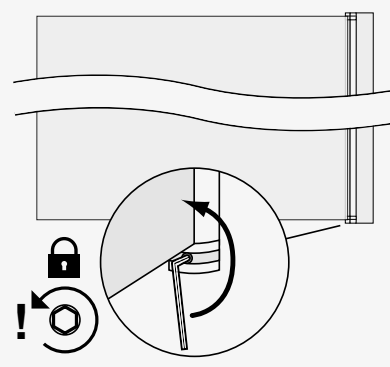

! (SV) **Låsa:** moturs.  
 (EN) **Lock:** anticlockwise.

# 11

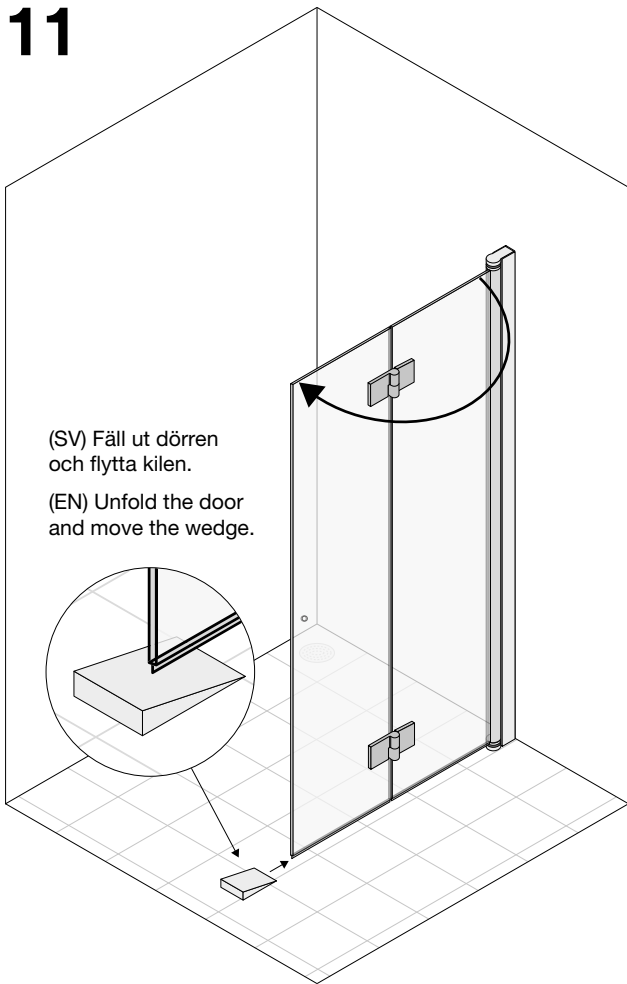

(SV) Fäll ut dörren och flytta kilen.  
 (EN) Unfold the door and move the wedge.

# 12

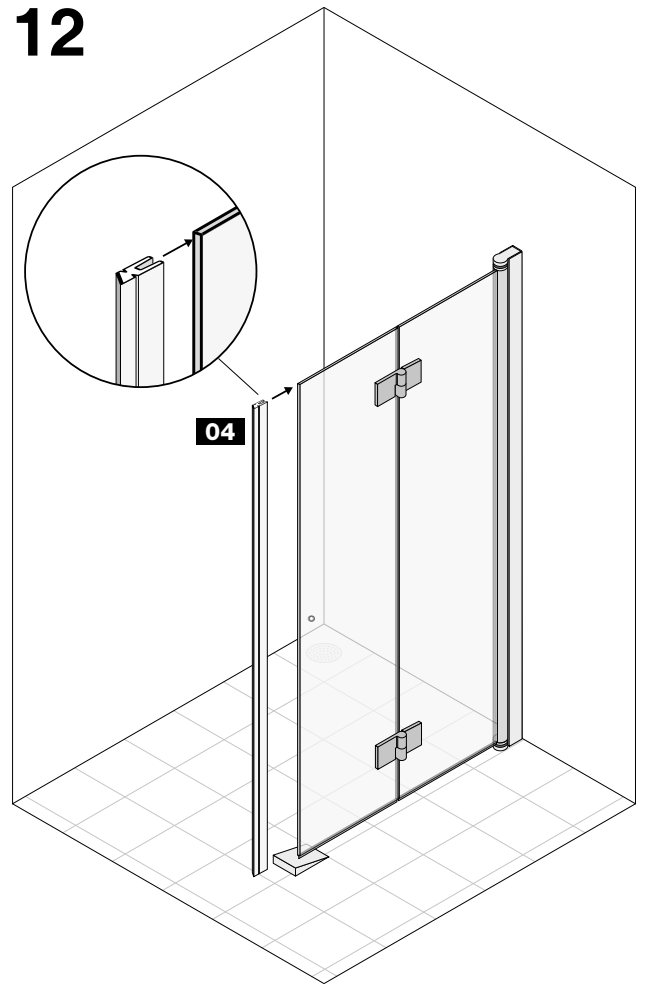

04

# 13

(SV) **ENDAST VID BEHOV!**

Gångjärnen mellan glassivorna kan justeras om glassivorna inte är helt parallella.

- 1) Ta loss täcklocken.
- 2) Lösgör gångjärnen med en torx-nyckel.
- 3) Placera tillfälligt de två positionsklossarna i plast högst upp och längst ner mellan glaset.
- 4) Justera glaset/gångjärnen.
- 5) Skruva fast torx-skruvarna.
- 6) Sätt tillbaka täcklocken.

(EN) **ONLY IF NECESSARY!**

The hinges between the glass plates can be adjusted in case the glass plates are not parallel.

- 1) Remove the covers.
- 2) Unfix the hinges with a torx key.
- 3) Temporarily place the two plastic pads at the top and bottom between the glasses.
- 4) Adjust the glasses/hinges.
- 5) Tighten the torx screws.
- 6) Put the covers back.

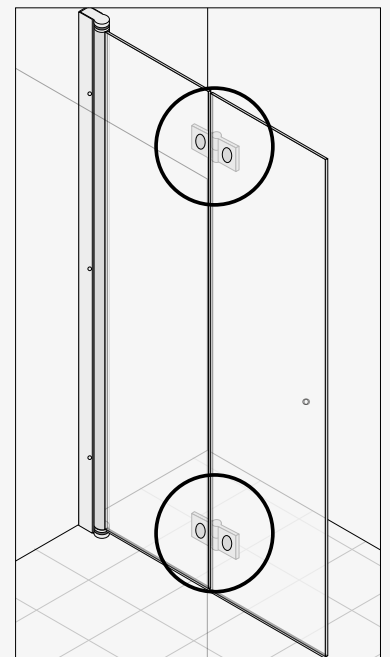
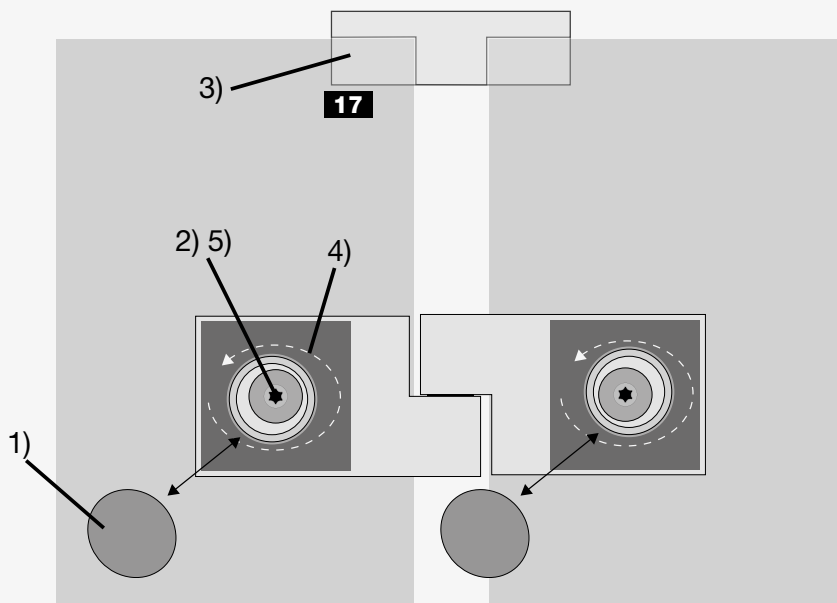

# 12

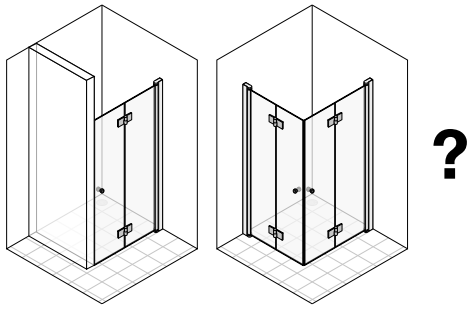

**(SV) Två duschväggar?**

Om du monterar en duschkörna med två duschväggar, monteras nu den andra duschväggen enligt tidigare instruktioner.

**(EN) Two shower walls?**

If you are mounting a shower corner with two shower walls, the second door should now be mounted according to previous instructions.

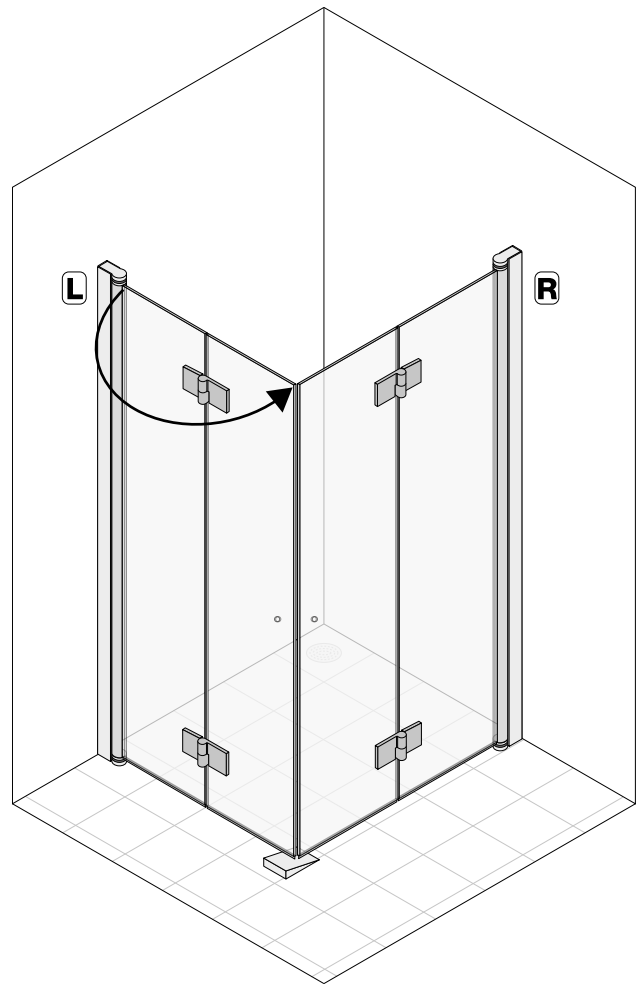

# 13

**(SV) FINJUSTERINGAR**

**Två duschväggar i hörn:** Justera duschväggarna så att deras ytterkanter möts och ligger parallellt (fig. A).

**En duschvägg i nisch:** Justera duschväggen så att dess ytterkant möts och ligger parallellt med motstående vägg.

Det går att dra ut väggen upp till 20 mm ur väggprofilen (fig. B och C). Det går även att vinkla dörren något (fig. D och E). Lägg till eller ta bort höjningsbrickor vid behov (2, 5, 7 mm).

**(EN) ADJUSTMENTS**

**Two shower walls in a corner:** Adjust the walls so that their outer edges meet and are parallel (fig. A).

**One shower wall in niche:** Adjust the wall so that its outer edge meets and is parallel to the opposite wall.

It is possible to pull out the wall up to 20 mm out of the wall profile (fig. B and C). It is also possible to adjust the angle of the door (fig. D and E).

If needed, add or remove elevation trays (2, 5, 7 mm).

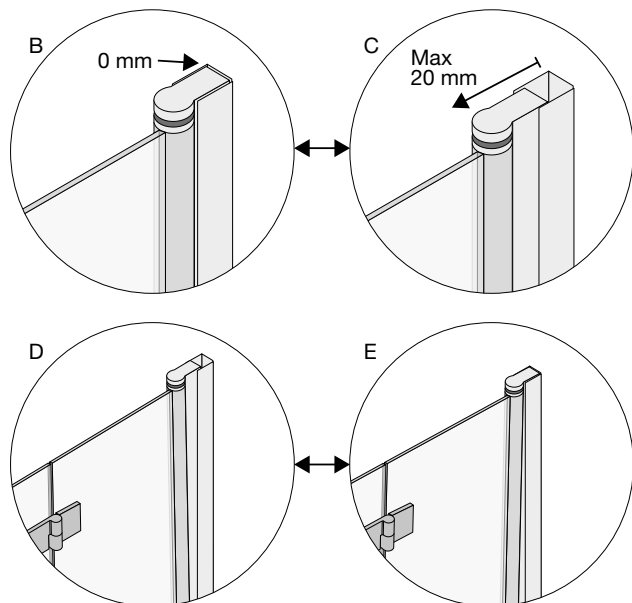
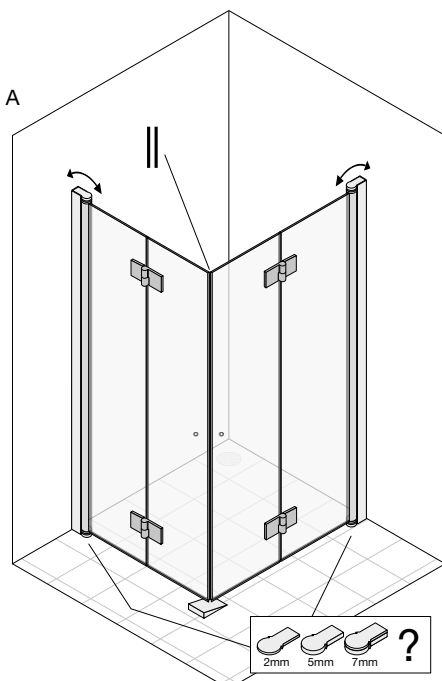



# 14

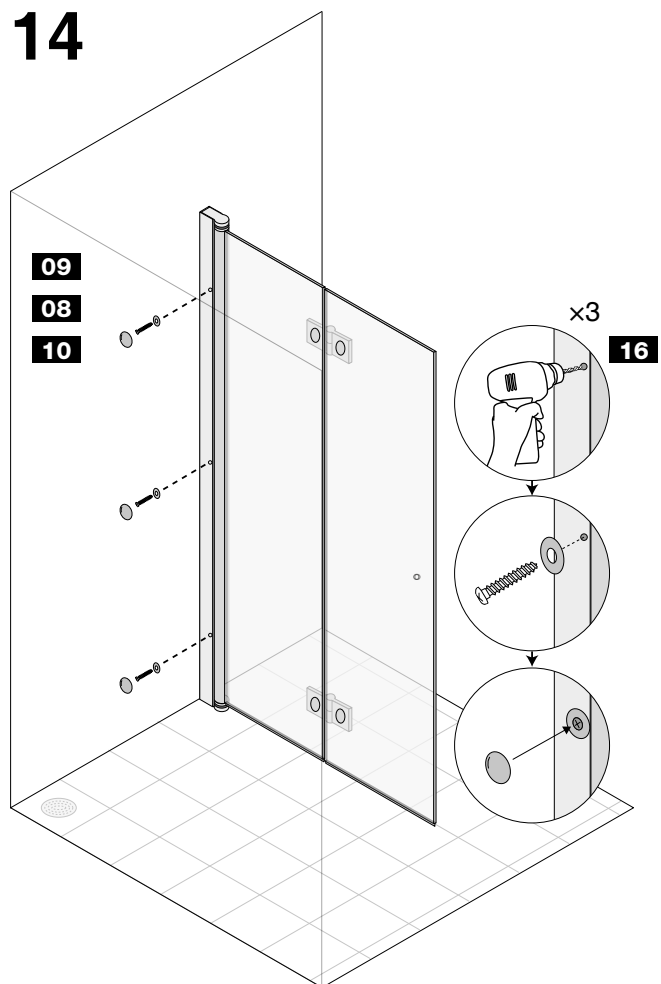

(SV) När dörren (eller båda dörrarna) är justerade, borra med en bormaskin genom väggprofilens förborrade hål så att du kan skruva fast dörren i väggprofilen. Ta bort kilen.

(EN) When the door (or both doors) are adjusted, use a drill machine through the pre-bored holes in the wall profile so that you can fix the door into the wall profile with the screws. Remove the wedge.

# 15

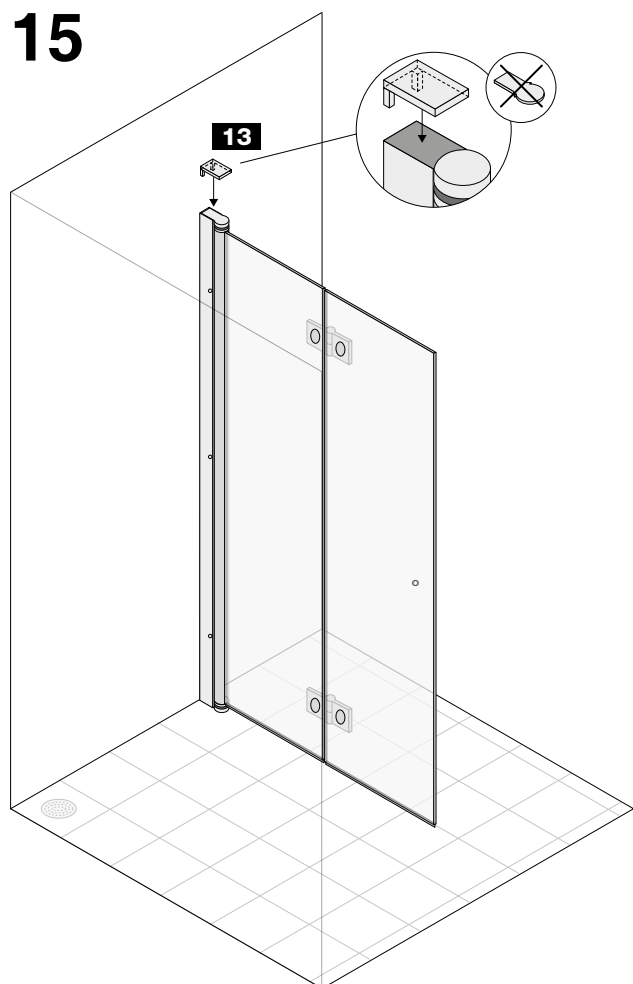

# 16

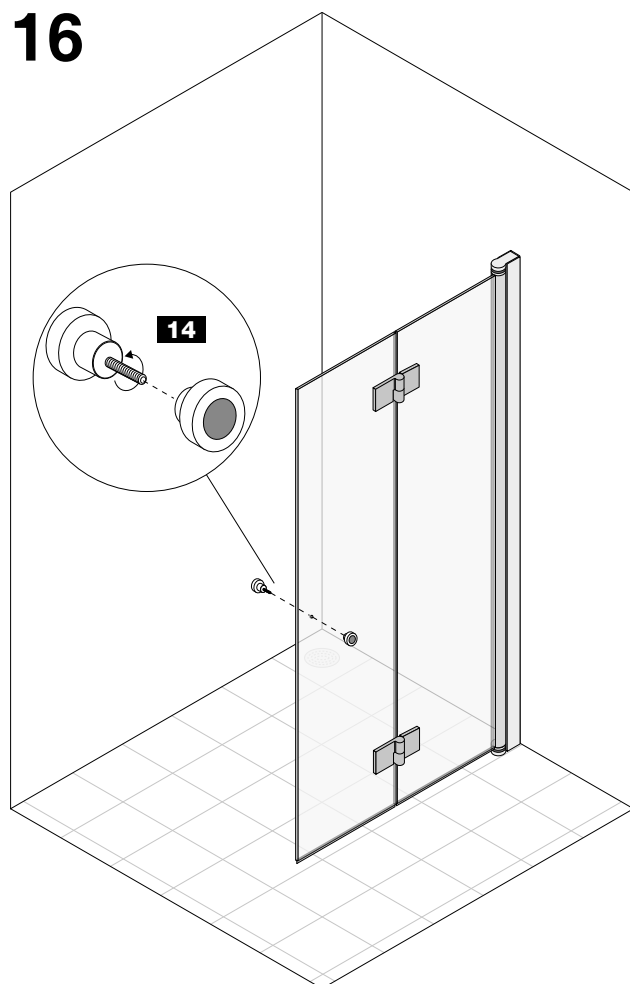

# 17

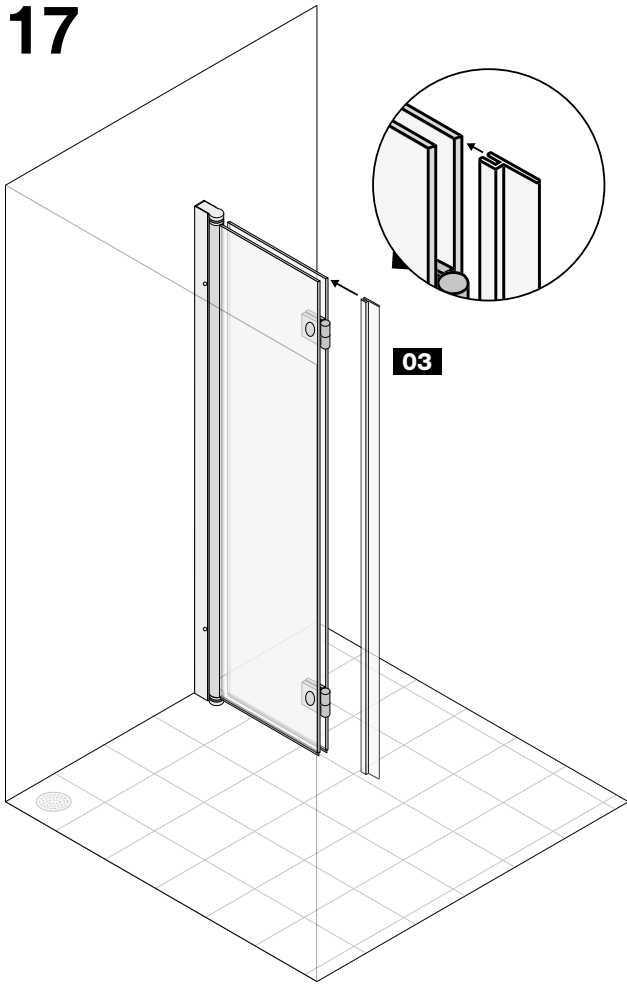

# 18

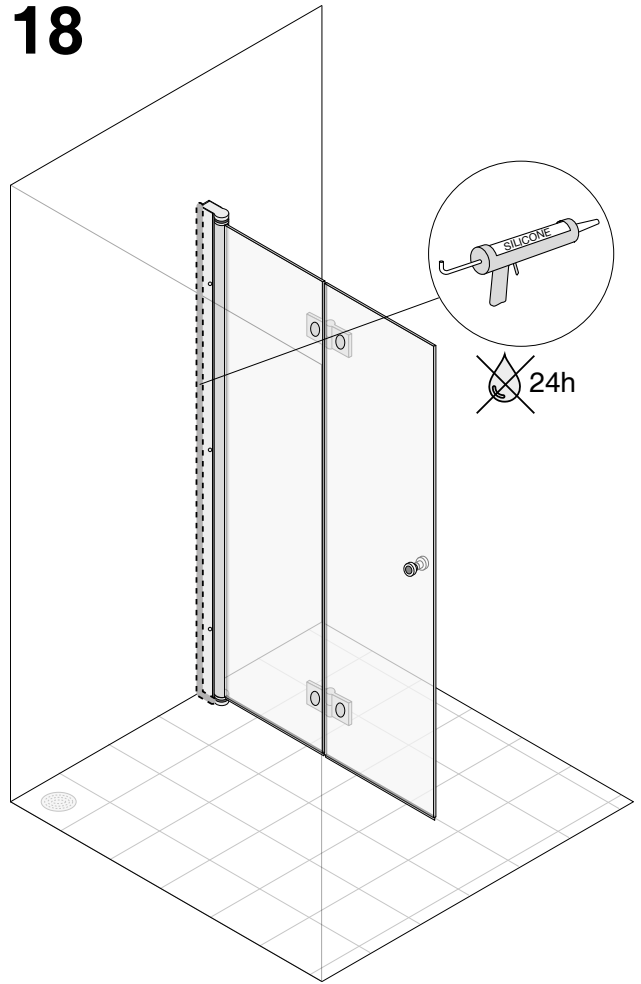

# 19

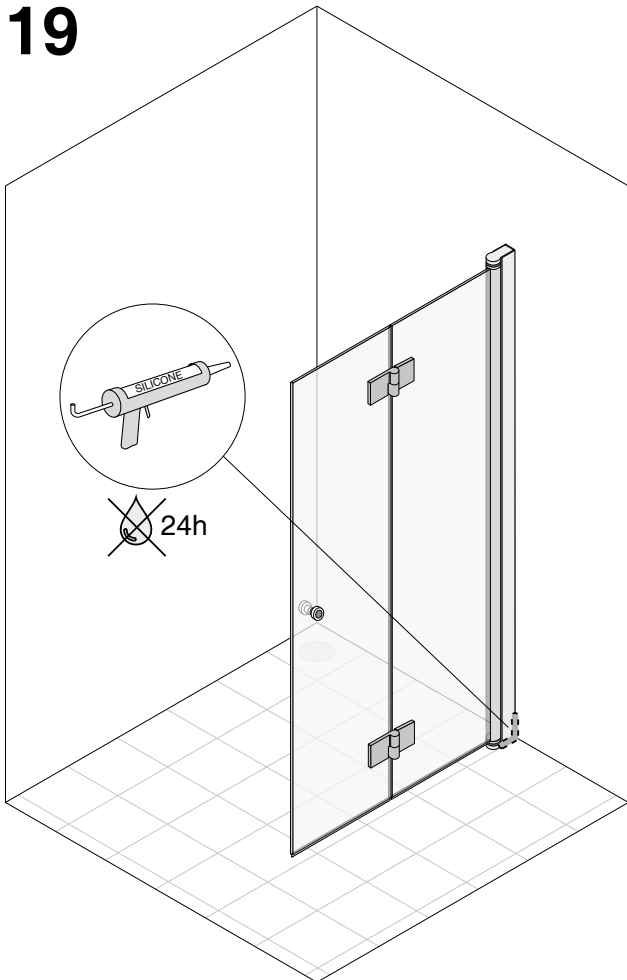

# 20

(SV) **ENDAST VID BEHOV**

Rördragning genom väggprofilen. Använd silikon.

(EN) **ONLY IF NECESSARY!**

Piping through the wall profile. Use silicone.

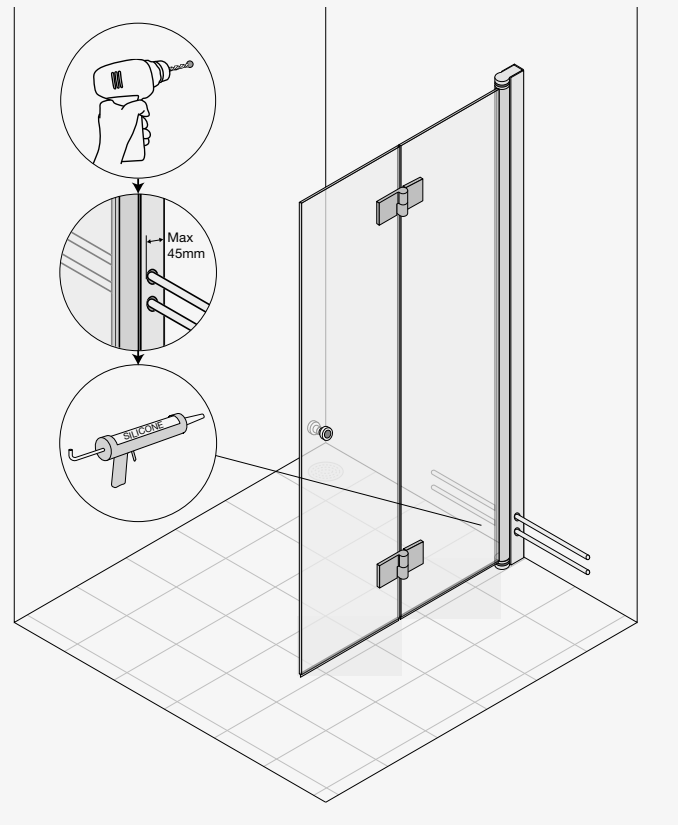

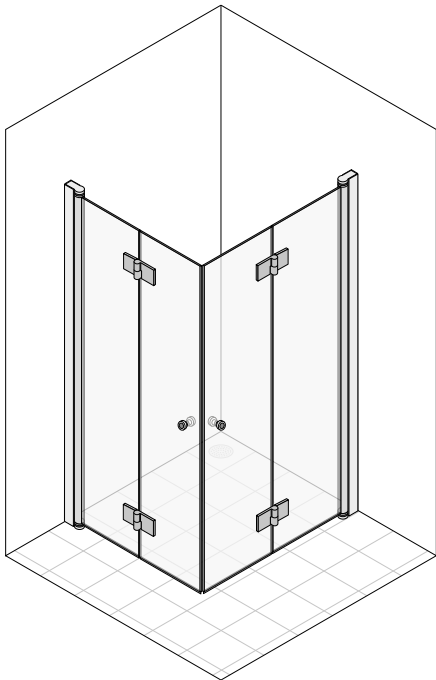

Twice Corner

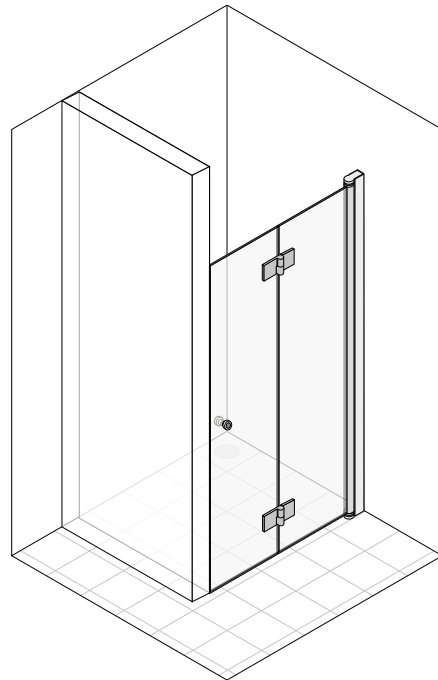

Twice Nisch

